

(19) World Intellectual Property Organization
International Bureau



(43) International Publication Date
27 March 2008 (27.03.2008)

PCT

(10) International Publication Number
WO 2008/036384 A2

(51) International Patent Classification:
A61B 17/00 (2006.01)

(74) Agents: FROST, Kathleen, A. et al.; Stallman & Pollock
Llp, 353 Sacramento Street, Suite 2200, San Francisco, CA
94111 (US).

(21) International Application Number:
PCT/US2007/020440

(81) Designated States (unless otherwise indicated, for every
kind of national protection available): AE, AG, AL, AM,
AT, AU, AZ, BA, BB, BG, BH, BR, BW, BY, BZ, CA, CH,
CN, CO, CR, CU, CZ, DE, DK, DM, DO, DZ, EC, EE, EG,
ES, FI, GB, GD, GE, GH, GM, GT, HN, HR, HU, ID, IL,
IN, IS, JP, KE, KG, KM, KN, KP, KR, KZ, LA, LC, LK,
LR, LS, LT, LU, LY, MA, MD, ME, MG, MK, MN, MW,
MX, MY, MZ, NA, NG, NI, NO, NZ, OM, PG, PH, PL,
PT, RO, RS, RU, SC, SD, SE, SG, SK, SL, SM, SV, SY,
TJ, TM, TN, TR, TT, TZ, UA, UG, US, UZ, VC, VN, ZA,
ZM, ZW.

(22) International Filing Date:
21 September 2007 (21.09.2007)

(25) Filing Language: English

(26) Publication Language: English

(30) Priority Data:
60/826,535 21 September 2006 (21.09.2006) US

(71) Applicant (for all designated States except US):
SYNECOR, LLC [US/US]; 3908 Patriot Drive, Suite
170, Durham, NC 27703 (US).

(84) Designated States (unless otherwise indicated, for every
kind of regional protection available): ARIPO (BW, GH,
GM, KE, LS, MW, MZ, NA, SD, SL, SZ, TZ, UG, ZM,
ZW), Eurasian (AM, AZ, BY, KG, KZ, MD, RU, TJ, TM),
European (AT, BE, BG, CH, CY, CZ, DE, DK, EE, ES, FI,
FR, GB, GR, HU, IE, IS, IT, LT, LU, LV, MC, MT, NL, PL,
PT, RO, SE, SI, SK, TR), OAPI (BF, BJ, CF, CG, CI, CM,
GA, GN, GQ, GW, ML, MR, NE, SN, TD, TG).

(72) Inventors; and

(75) Inventors/Applicants (for US only): WILLIAMS,
Michael, S. [US/US]; 6793 St. Helena Road, Santa Rosa,
CA 95404 (US). ORTH, Geoffrey, A. [US/US]; 5800
Lone Pine Road, Sebastopol, CA 95472 (US). GLENN,
Richard, A. [US/US]; 1519 Branch Owl Place, Santa
Rosa, CA 95409 (US). SMITH, Jeffrey, A. [US/US]; 330
Keller Street, Petaluma, CA 94952 (US).

Published:

— without international search report and to be republished
upon receipt of that report

(54) Title: STOMACH WALL CLOSURE DEVICES

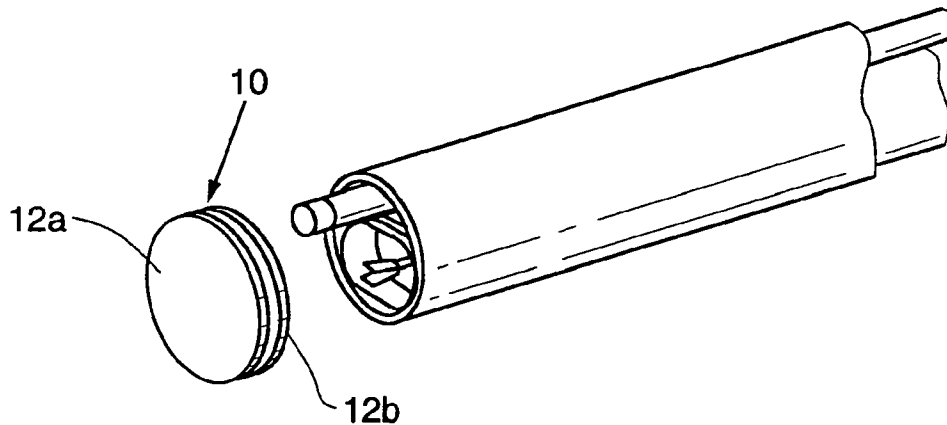

(57) Abstract: In a method for sealing an incision in an interior body wall such as a gastrotomy opening in a stomach, a closure device is positioned within the incision. The closure device includes a seal and an anchor coupled to the seal. The seal is positioned in sealing contact against a first surface of the body wall, and the anchor is positioned against the second surface of the body wall such that a portion of the closure device is positioned. The closure device seals the incision while healing takes place. Once the incision is significantly healed, the closure device bioerodes.



WO 2008/036384 A2

Fig. 2A is a perspective view showing the closure device of Fig. 1A in a folded configuration and positioned next to a deployment system for use in placing the closure device in an abdominal wall incision.

5 Figs. 2B through 2G are a sequence of perspective drawings illustrating deployment of the closure device of Fig. 1A using the Fig. 2A system.

Fig. 3 is a cross-section view of a portion of stomach wall and illustrates the closure device of Fig. 1A after it has been positioned as described in connection with Figs. 2A through 2G.

10 Fig. 4A is a perspective view of a second embodiment of a closure device.

Fig. 4B shows a side elevation view of the closure device of Fig. 4A.

Fig. 5 is an exploded perspective view of a third embodiment of a closure device.

Fig. 6A is a side elevation view of a fourth embodiment of a closure device positioned in a stomach wall incision.

Fig. 6B shows the closure device of Fig. 6A positioned in a delivery cannula.

15 Fig. 6C shows the closure device of Fig. 6A deployed in a stomach wall incision.

Fig. 6D is a side view similar to Fig. 6B showing a modification to the Fig. 6A embodiment positioned in a delivery cannula.

Fig. 7A is a perspective view of a fifth embodiment of a closure device.

20 Fig. 7B is a side elevation view showing the Fig. 7A closure device positioned through an incision in a stomach wall.

Figs. 8A and 8B are views similar to Figs. 7A and 7B showing the closure device of the fifth embodiment during folding of the distal wing.

Figs. 9A and 9B are views similar to Figs. 7A and 7B showing the closure device of the fifth embodiment following folding of the distal wing.

25 Fig. 10A is a top plan view of a sixth embodiment of a closure device.

Fig. 10B is a side elevation view of the closure device of Fig. 10A.

Fig. 10C is a plan view similar to Fig. 10A showing the closure device, disposed in an incision through a stomach wall, following folding of the distal wing.

30 Fig. 11 is a perspective view showing a seventh embodiment of a closure device being inserted through an incision in a stomach wall.

Fig. 12A is a top plan view showing the closure device of Fig. 11 positioned in an incision.

Fig. 12B is similar to Fig. 12A and shows the closure device being collapsed to a

DETAILED DESCRIPTION

The present application describes a number of closure devices that may be endoscopically implanted (preferably in a transoral procedure) to close an incision or
5 other type of opening or puncture in an interior body wall such as a stomach wall. For simplicity, any type of opening formed in the body wall will be referred to as an incision. The descriptions given herein will be described as a gastrotomy closure device for closing incisions formed in stomach walls, although the devices and associated methods are suitable for use in closing incisions in other body walls (e.g. the uterus, vagina, colon or
10 other parts of the intestinal tract) as well.

In general, closure devices of the type described herein comprise a pair of expandable portions, one of which is positioned inside the stomach and the other of which is positioned on the stomach exterior. A connecting feature extends between the expandable portions and is generally positioned extending through the incision. The
15 closure devices seal the incision preventing passage of fluids or material from stomach into the peritoneal cavity while the incision heals. They are preferably bioabsorbable/bioerodible implants so that they disappear once sufficient healing has taken place, but they may instead be permanent implants. In this disclosure, the term "bioerodible" will be used to describe any type of material that absorbs, degrades, erodes,
20 etc. within the body over time. In some embodiments, the closure device additionally forms a platform or scaffold onto or through which tissue can grow during the healing process.

Figs 1A – 1C illustrate a first embodiment of a closure device 10, which includes a pair of wings 12a, 12b and a connecting element 14 of any of a number of shapes
25 extending between the wings. Wings 12a, 12b are shown as having an oval shape, although other shapes including, but not limited to, elliptical or circular shapes may be used. Also, the proximal wing 12b (or "interior" wing since it is placed in the stomach interior) may have a shape or configuration different from that of the distal (or "exterior") wing 12a as described in the various embodiments discussed below.

30 In the first embodiment, the connecting element 14 is an elongate rib proportioned so that it may be positioned within an incision in the stomach. While not mandatory, the elongate shape of the rib is particularly suitable for a closure device used to close an elongate cut or tear in the tissue. The dimensions for the closure device are selected such

sheath 28. Use of the system 18 will next be described.

In preparation for deployment, the closure device 10 is folded as described above, and the proximal wing 12b to be deployed in the stomach interior is engaged in its folded state by grasper 22. The grasper 22 and a portion of the device 10 (including wing 12b) is withdrawn into the delivery cannula 20, leaving distal wing 12a positioned outside the distal opening of the delivery cannula 20. The delivery cannula 20 and the folded closure device 10 are positioned within the intermediate sheath 28 so as to maintain the folded configuration of the device 10. The intermediate sheath 28 and endoscope are positioned within the outer sheath 24 as shown in Fig. 2B.

The distal end of the outer sheath 24 is passed through the mouth and esophagus and into the stomach. As shown in Fig. 2C, the intermediate sheath 28 is advanced out of the outer sheath 24 and through the incision (not shown) under visualization using the endoscope 26. At this stage the device 10 is within the intermediate sheath 28, along with the grasper 22 and delivery cannula 20, neither of which is visible in Fig. 2C. Referring to Fig. 2D, the intermediate sheath 28 is next withdrawn, exposing the exterior wing 12a of the device 10, causing the wing to expand on the exterior of the stomach to the position shown in Fig. 6. The delivery cannula 20 is withdrawn as shown in Fig. 2E, but the interior wing 12b remains folded because it remains within the jaws of the grasper 22. Traction is applied to the grasper to pull the exterior wing 12a into contact with the stomach wall. The grasper 22 is then actuated to release the wing 12b, causing it to expand in the stomach interior (Fig. 2F), leaving the device positioned within the incision as shown in Fig. 3. One or both of the wings 12a, 12b forms a seal with the stomach wall to prevent leakage of stomach contents into the peritoneal space. The elongate shape of the rib 14, which extends through the incision, helps to maintain the alignment of the sides of the incision. As the incision heals, tissue grows through the slots 16. Over time, the device degrades or absorbs within the body.

A second embodiment of a closure device 10b is shown in Fig. 4A and 4B. Closure device 10b is similar to the first embodiment, except that the slots 16 of the first embodiment are replaced with a plurality of openings 16b in the rib 14. The openings 16b are positioned on the side of the rib closest to wing 12a. When the closure device is deployed, this configuration places the openings adjacent to the serosal tissue lining the exterior surface of the stomach. The openings thus create access through the device for serosal tissue bonding as serosal tissue grows through the openings from opposite sides of

illustrated in Figs. 8A and 8B. Folding preferably continues until the strip 32b collapses into a double layer wing as shown in Figs. 9A and 9B. Knots 35 or other locking features on suture 34a contact the proximal surface of wing 12b, preventing reopening of the distal wing 12a.

5 Figs. 10A-10C illustrate an alternative to the Fig. 7A – 9B embodiment, in which the distal wing 12a is also formed using strip 32a, but in which only one end of the strip 32a is coupled to the proximal wing 12b. In this embodiment, suture 34a is positioned to causes the strip 32a to fold to form the distal wing 12a when tension is applied to the suture 34a. For example, in the illustrated embodiment, suture 34a extends in a
10 rectangular U-shaped pattern, with the lateral connector 39 of the “U” positioned near the distal end of the strip as shown in Fig. 10B. Each leg of the “U” extends along a first face of the strip 32a, then passes through the strip material and extends along the opposite face of the strip before passing again through the strip material.

To close an incision using the Fig. 10A-10C embodiment, the strip 32a is inserted
15 through the incision and the proximal wing 12b is placed against the interior stomach wall as described above. When tension is applied to the end portions of the suture (see the arrows in Figs. 10B and 10C), the strip 32a folds one or more times into a predetermined shape and seats against the exterior wall of the stomach, forming exterior wing 12a. For example, the Fig. 10A – 10C embodiment is configured such that the lateral connector 39
20 of the “U” of the suture folds the distal end of the strip 32a into an orientation that is generally parallel the proximal wing 12b. As with the prior embodiments, the knots 35 engage with proximal wing 12b to lock the strip

In the alternate embodiment of Figs. 11– 12C, strip 32a functions as both the proximal wing 12b and the distal wing 12a. As with the previous embodiment, a pullwire
25 such as suture 34a is employed to collapse or fold the strip into a desired arrangement. The strip 32a is fed through the incision as illustrated in Fig. 11, and the suture is withdrawn to collapse the strip as shown in Fig. 12B. With the suture pattern shown in Figs. 11 -12C, full retraction of the suture places folds 41a, 41b in the strip 32a. The distal and proximal ends 43a, 43b of the strip preferably overlap the incision to facilitate
30 sealing of the incision.

As illustrated in Figs. 13 – 15, the closure device may be provided with features that facilitate sealing between the closure device and the stomach wall. For example, as shown in Fig. 13, inner wing 12b (or the outer wing if preferred) may include an annular

In another embodiment shown in Figs. 20A, 20B, the closure device 58 is a tubular braid having proximal and distal collars 60a, 60b. When expanded, the device 58 includes a narrow waist 62 formed by a restrictor band as shown, or by tapered construction of the braid material. The closure device is expanded by shortening the distance between the collars 60a, 60b using one of many techniques. Using the technique shown in Fig. 20bB, collar 60b is held in a fixed position on detachable mandrel 66 while collar 60a is advanced distally along the mandrel. The mandrel is detached following expansion.

In alternative embodiments, a closure device similar to the closure device of Fig. 1A may have wings joined together using a rib formed of one or more pairs of interlocking pieces. Various configurations for interlocking ribs are shown in Figs. 21A through 22C.

In another example of a two piece closure device illustrated in Fig. 24A, each of the wings 70, 72 may be threaded onto one or more barbed strands 74. With the wing 70 positioned outside the stomach and the strands extending through the incision, tension is applied to the strands as the wing 72 is pushed towards the stomach wall using a pusher 76. As illustrated in Fig. 24B, improved control over the pusher may be had by threading the pusher 76 onto the strands 74. As the wings 70, 72 are brought together, a rib 78 on one of the wings 70 extends through the incision and contacts the other wing 72. The rib 78 may slide into a corresponding recess 80 or interlocking feature in the wing 72. The barbed strands act as a "zip tie", allowing the wings to be retained in a desired relationship relative to one another giving the user the ability to choose the amount of tissue compression to be used. Once the wings are positioned and the strands 74 tightened, the loose ends of the stands are clipped and removed from the body.

Figs. 24C and 24D illustrate that the wings 70, 72 may be shaped such that when they are tightened against the tissue, their central regions bow inwardly to facilitate sealing of the incision. Figs. 23A and 23B illustrate that the wings 70, 72, with the strands 74 coupled to them, may be positioned in a delivery cannula 20 for deployment.

Figs. 25A and 25B illustrated an alternative two-piece design in which the wings 70, 72 are joined together within the body using a screw connection 80a, 80b.

In any of the disclosed the devices, sealing contact between the stomach wall and either or both of the proximal and distal wings/anchors may be enhanced through the use of adhesives. The adhesive may be a slowly degrading cyanoacrylate such as octyl-2-

We Claim:

1. A method for sealing an incision in an interior body wall, the method comprising:
identifying an incision in a body wall within a living body wall, the body wall
5 having first and second surfaces;
positioning a closure device within the incision having a seal and an anchor
coupled to the seal, positioning the closure device including positioning the seal against
the first surface in a position covering the incision, and positioning the anchor against the
second surface such that a portion of the closure device is positioned extending through
10 the incision.
2. The method according to claim 1, wherein the method includes placing the closure
device within a cannula, and wherein positioning the closure device includes advancing a
distal end of the cannula through the incision, advancing one of the anchor and the seal
15 from the cannula, withdrawing the distal end of the cannula through the incision and
advancing the other of the seal and the anchor from the cannula.
3. The method according to claim 1, wherein position the anchor against the second
surface causes the anchor to seal against the second surface in a position covering the
20 incision.
4. The method according to claim 1, wherein the closure device degrades following
healing of the incision.
- 25 5. The method according to claim 1, wherein the body tissue grows through at least a
portion of the closure device during healing of the incision.
6. The method according to claim 1 wherein the body wall is selected from a group
of body walls consisting of a stomach wall, intestinal wall, and uterine wall.
30
7. The method according to claim 1, wherein positioning the anchor includes passing
the anchor through the incision and then expanding the anchor to anchor the closure
device within the incision.

17. The closure system of claim 11, wherein the anchor includes a strip coupled to the seal, the strip extendable through the incision, and an element coupled to the strip, the strip compressible upon application of tension to the element to cause folding of the strip.
- 5
18. The closure system of claim 16, wherein the strip includes a distal portion and a proximal portion, the strip positionable with the distal portion adjacent the second side and the proximal portion adjacent the first side, the strip compressible upon application of tension to the element to cause folding of the distal portion to form the anchor, and to
- 10 cause folding of the proximal portion to form the seal.
19. The closure system of claim 11, further including instructions for use instructing a user to position the seal against the first surface in a position covering the incision and to position the anchor against the second surface.
- 15
20. The closure system of claim 11, wherein the instructions further instruct the user to adhere the seal to the first surface using an adhesive.
21. The closure system of claim 11, further including a delivery cannula of sufficient
- 20 length to extend through an oral cavity into a stomach having the incision.

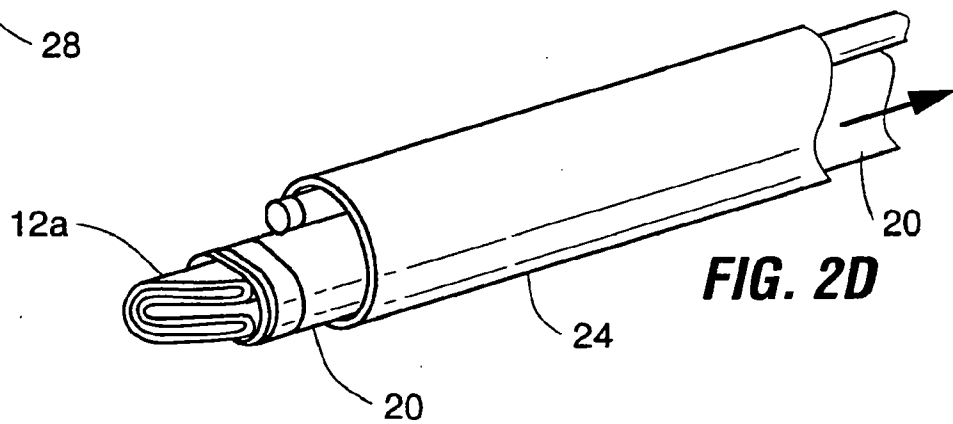
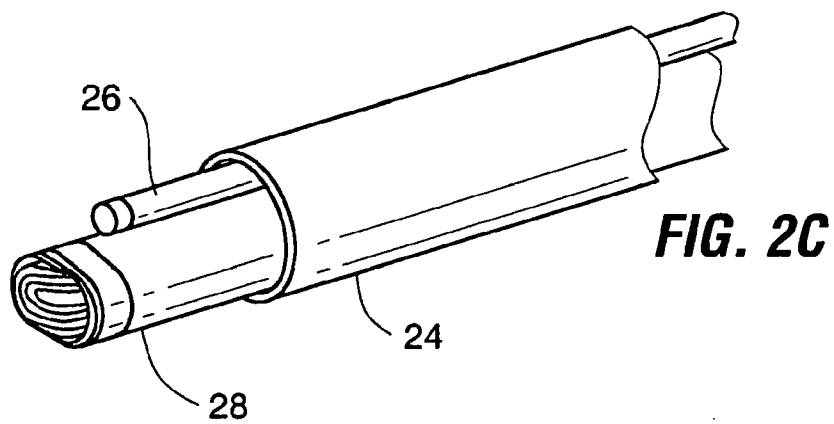
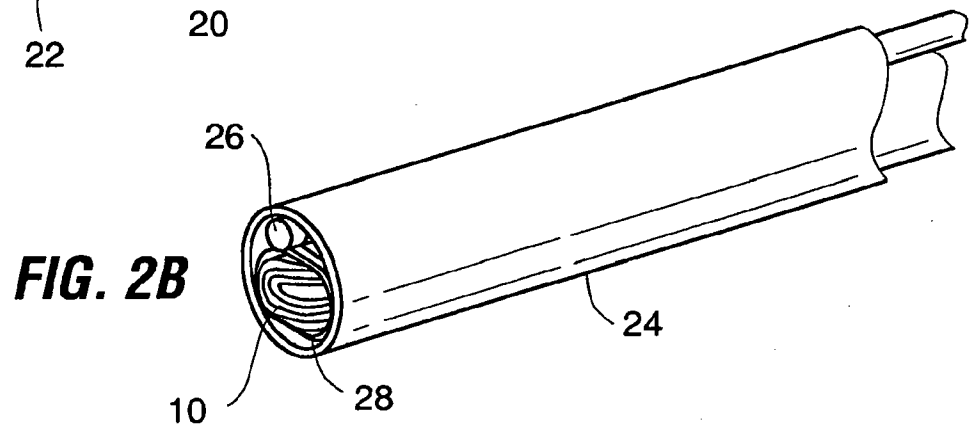
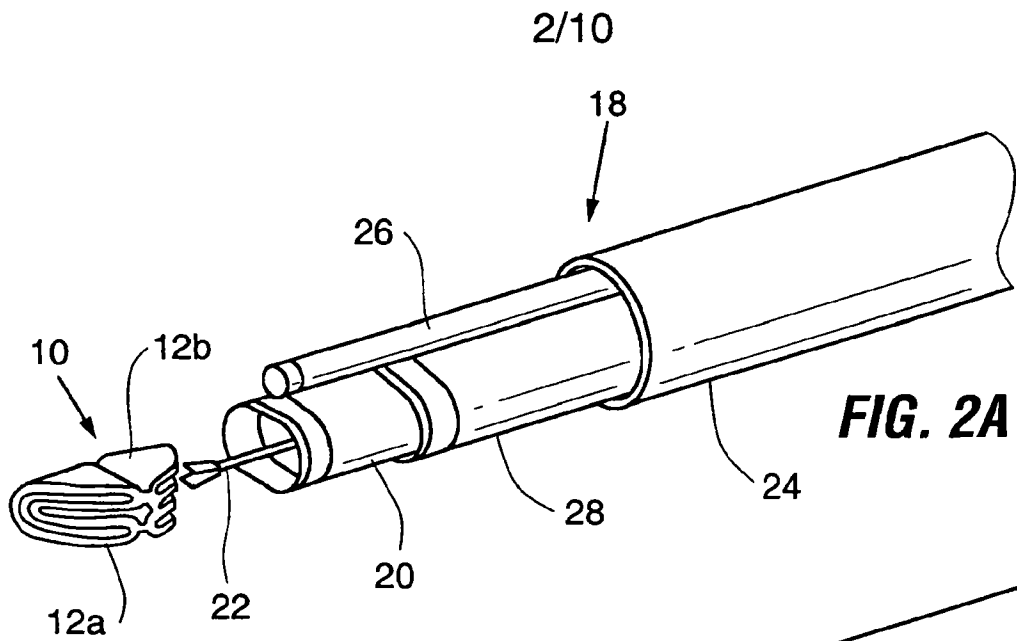

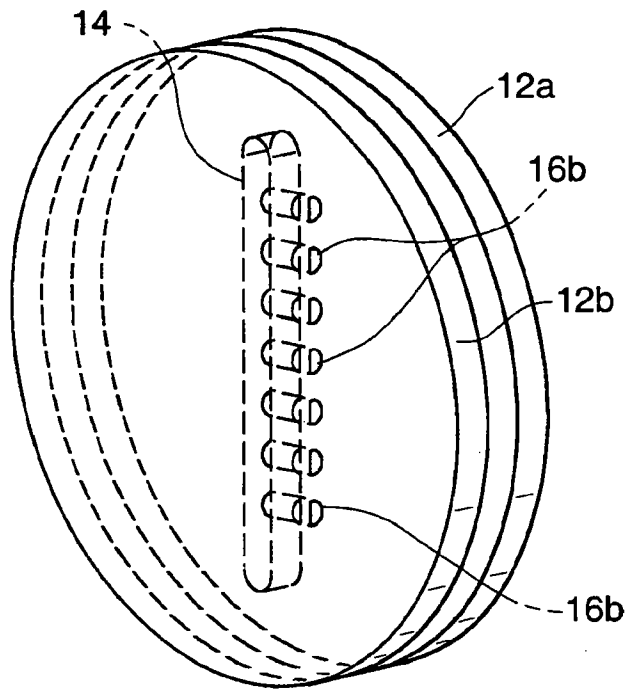

FIG. 4A

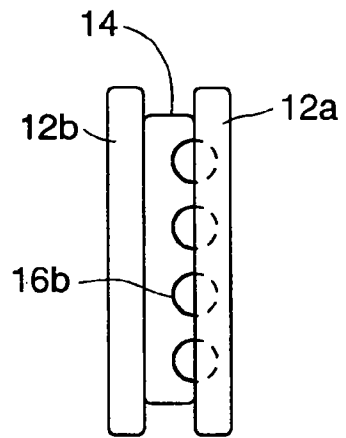

FIG. 4B

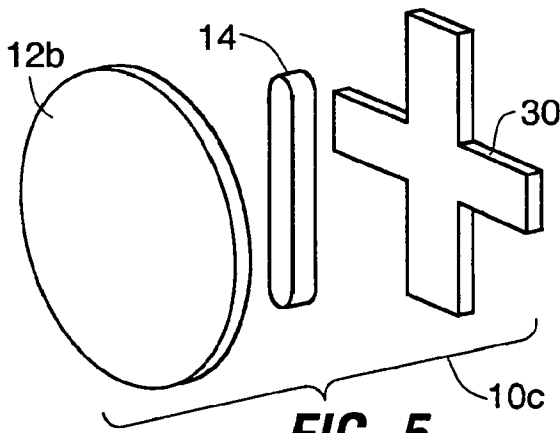

FIG. 5

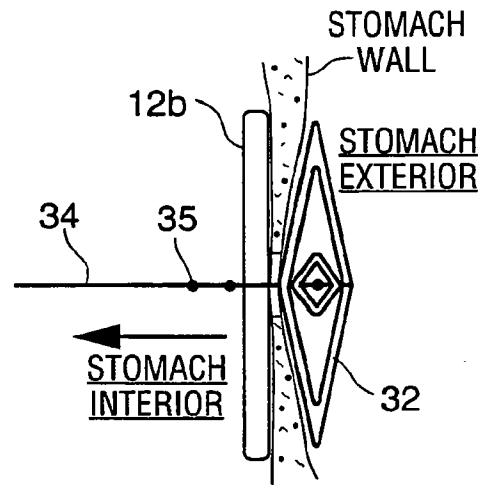

FIG. 6A

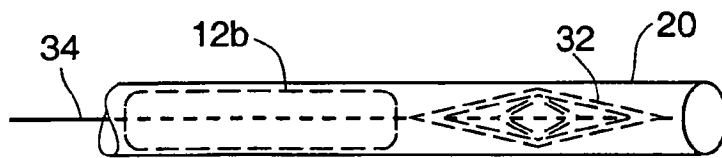

FIG. 6B

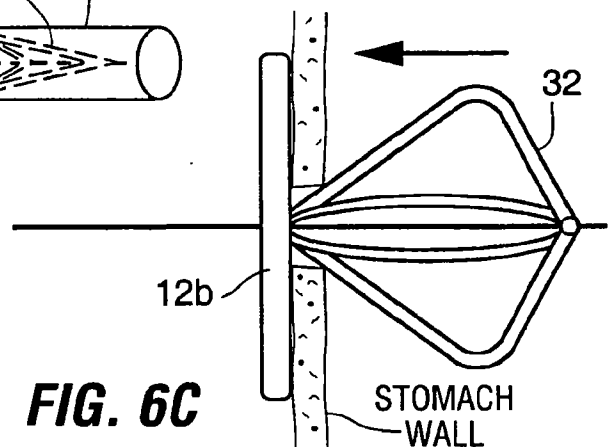

FIG. 6C

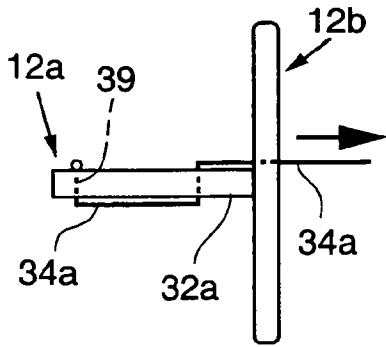

FIG. 10A

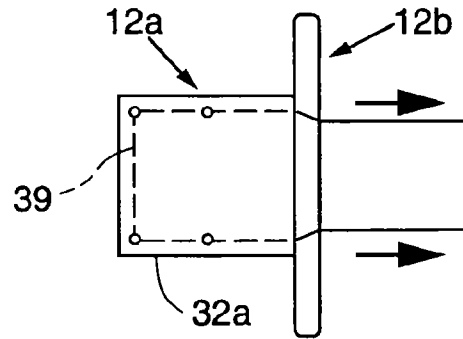

FIG. 10B

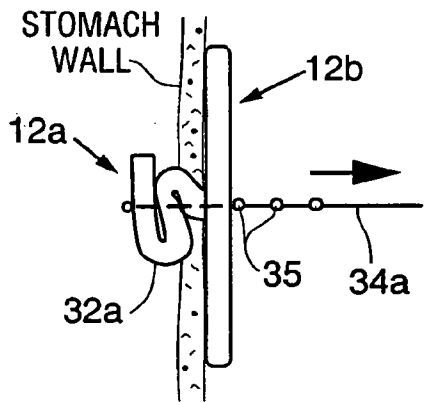

FIG. 10C

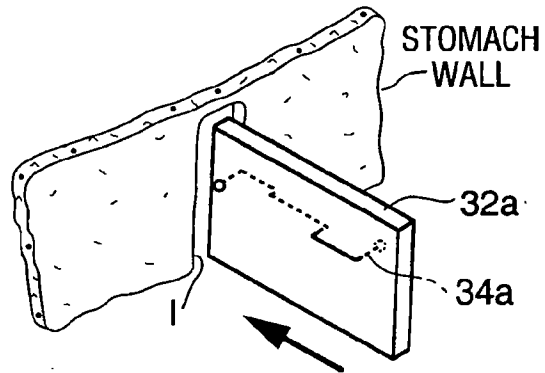

FIG. 11

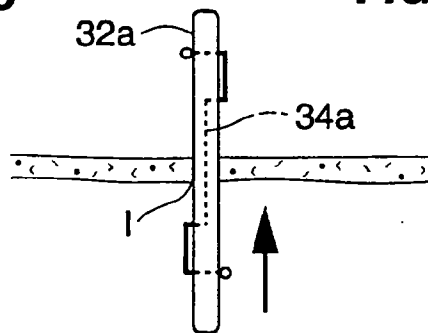

FIG. 12A

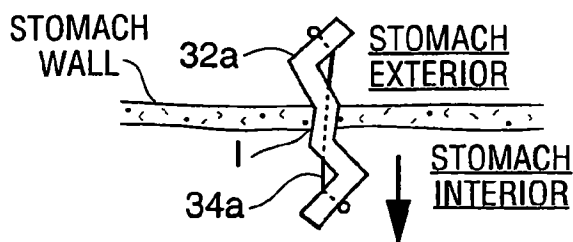

FIG. 12B

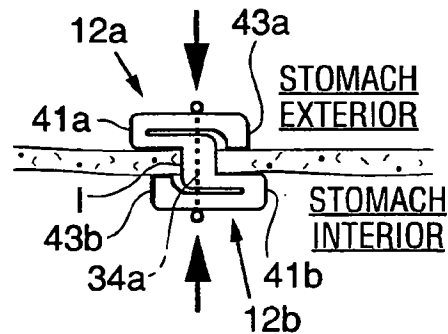

FIG. 12C

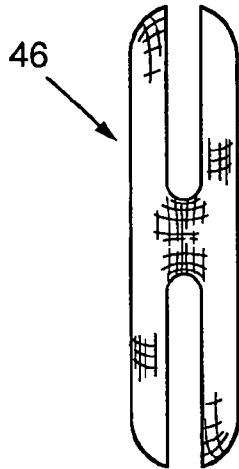

FIG. 18A

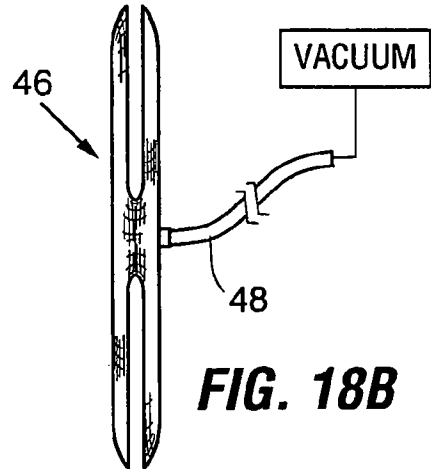

FIG. 18B

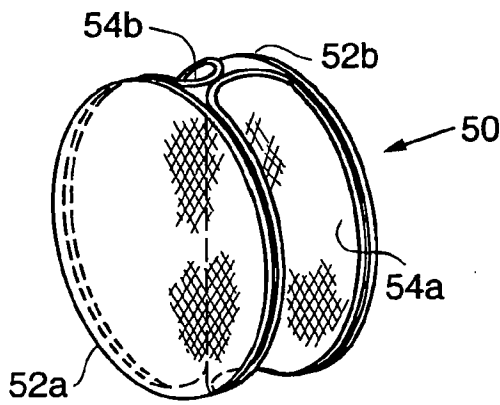

FIG. 19A

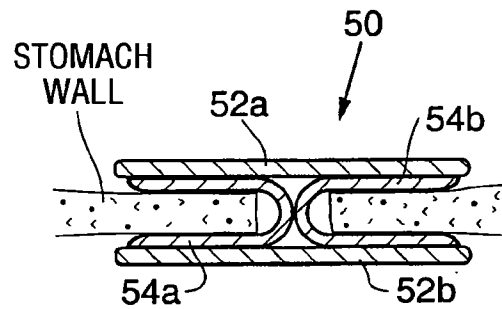

FIG. 19B

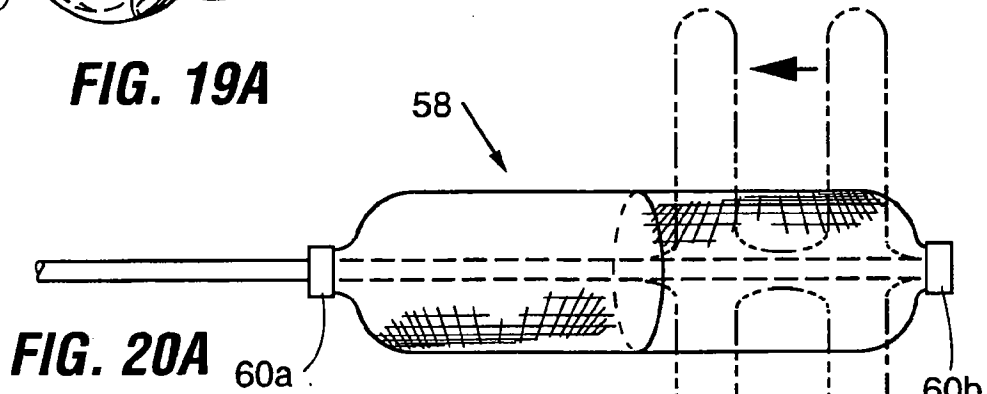

FIG. 20A

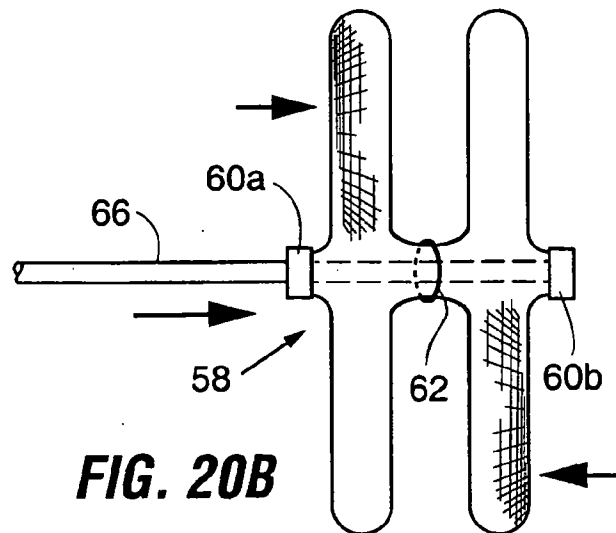
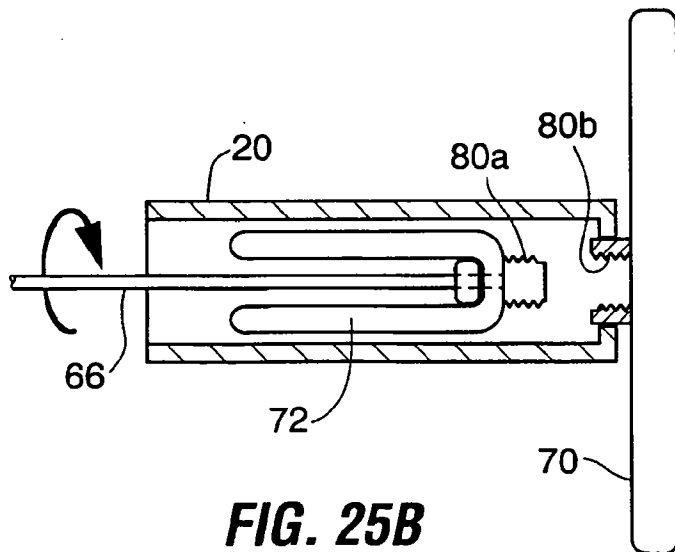
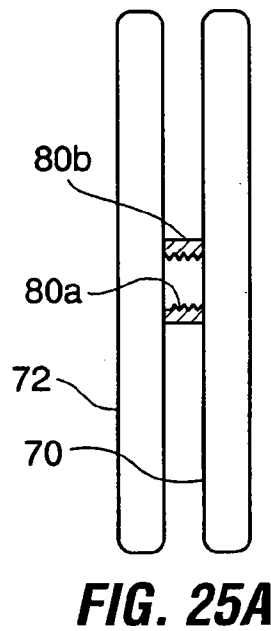
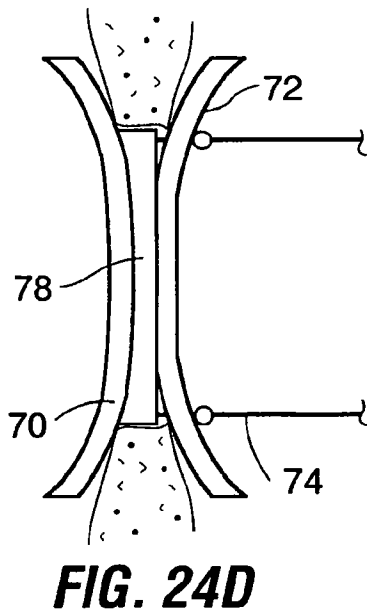
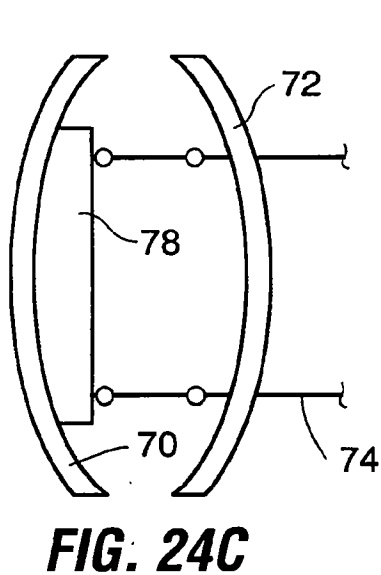
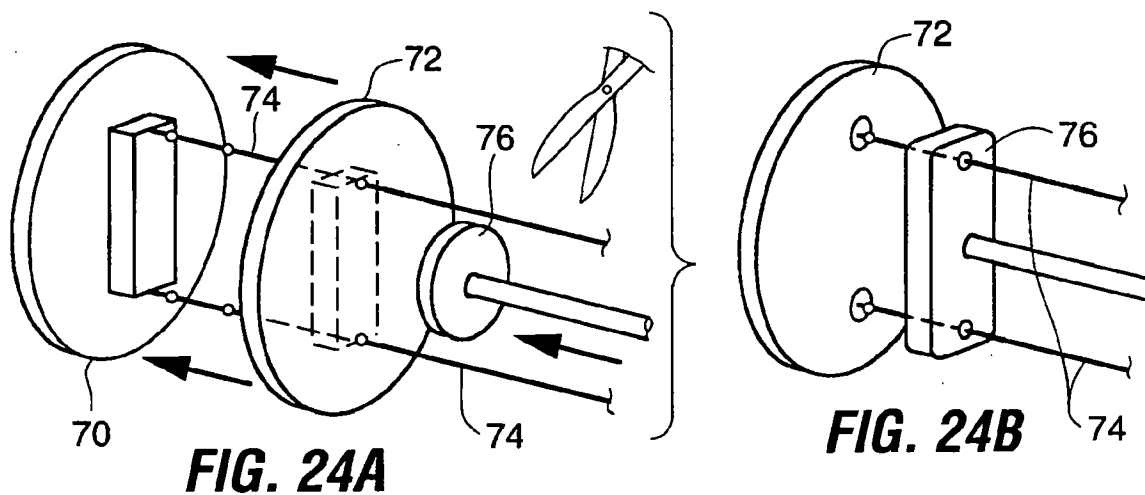

FIG. 20B



(19) World Intellectual Property Organization
International Bureau



(43) International Publication Date
27 March 2008 (27.03.2008)

PCT

(10) International Publication Number
WO 2008/036384 A3

(51) International Patent Classification:
A61B 17/00 (2006.01)

(21) International Application Number:
PCT/US2007/020440

(22) International Filing Date:
21 September 2007 (21.09.2007)

(25) Filing Language: English

(26) Publication Language: English

(30) Priority Data:
60/826,535 21 September 2006 (21.09.2006) US

(71) Applicant (for all designated States except US):
SYNECOR, LLC [US/US]; 3908 Patriot Drive, Suite 170, Durham, NC 27703 (US).

(72) Inventors; and

(75) Inventors/Applicants (for US only): WILLIAMS, Michael, S. [US/US]; 6793 St. Helena Road, Santa Rosa, CA 95404 (US). ORTH, Geoffrey, A. [US/US]; 5800 Lone Pine Road, Sebastopol, CA 95472 (US). GLENN, Richard, A. [US/US]; 1519 Branch Owl Place, Santa Rosa, CA 95409 (US). SMITH, Jeffrey, A. [US/US]; 330 Keller Street, Petaluma, CA 94952 (US).

(74) Agents: FROST, Kathleen, A. et al.; Stallman & Pollock LLP, 353 Sacramento Street, Suite 2200, San Francisco, CA 94111 (US).

(81) Designated States (unless otherwise indicated, for every kind of national protection available): AE, AG, AL, AM, AT, AU, AZ, BA, BB, BG, BH, BR, BW, BY, BZ, CA, CH, CN, CO, CR, CU, CZ, DE, DK, DM, DO, DZ, EC, EE, EG, ES, FI, GB, GD, GE, GH, GM, GT, HN, HR, HU, ID, IL, IN, IS, JP, KE, KG, KM, KN, KP, KR, KZ, LA, LC, LK, LR, LS, LT, LU, LY, MA, MD, ME, MG, MK, MN, MW, MX, MY, MZ, NA, NG, NI, NO, NZ, OM, PG, PH, PL, PT, RO, RS, RU, SC, SD, SE, SG, SK, SL, SM, SV, SY, TJ, TM, TN, TR, TT, TZ, UA, UG, US, UZ, VC, VN, ZA, ZM, ZW.

(84) Designated States (unless otherwise indicated, for every kind of regional protection available): ARIPO (BW, GH, GM, KE, LS, MW, MZ, NA, SD, SL, SZ, TZ, UG, ZM, ZW), Eurasian (AM, AZ, BY, KG, KZ, MD, RU, TJ, TM), European (AT, BE, BG, CH, CY, CZ, DE, DK, EE, ES, FI, FR, GB, GR, HU, IE, IS, IT, LT, LU, LV, MC, MT, NL, PL, PT, RO, SE, SI, SK, TR), OAPI (BF, BJ, CF, CG, CI, CM, GA, GN, GQ, GW, ML, MR, NE, SN, TD, TG).

Published:

- with international search report
- before the expiration of the time limit for amending the claims and to be republished in the event of receipt of amendments

(88) Date of publication of the international search report:
24 July 2008

(54) Title: STOMACH WALL CLOSURE DEVICES

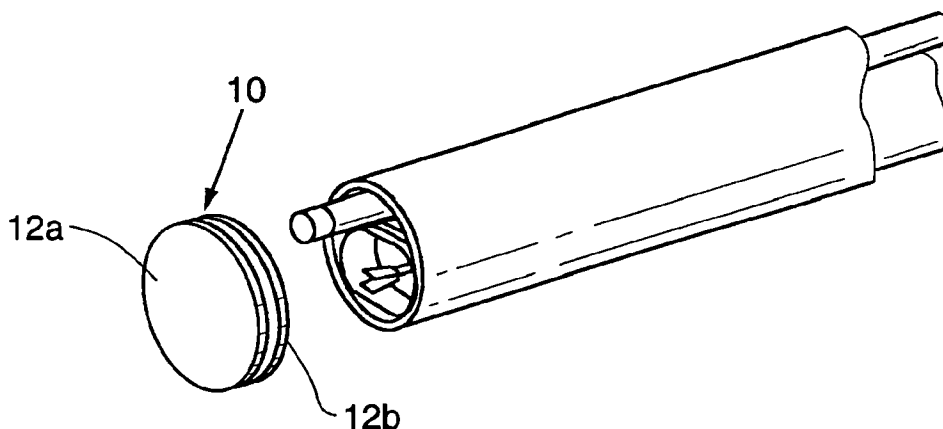

(57) Abstract: In a method for sealing an incision in an interior body wall such as a gastrotomy opening in a stomach, a closure device (10) is positioned within the incision. The closure device includes a seal (12b) and an anchor (12a) coupled to the seal. The seal is positioned in sealing contact against a first surface of the body wall, and the anchor is positioned against the second surface of the body wall such that a portion of the closure device is positioned. The closure device seals the incision while healing takes place. Once the incision is significantly healed, the closure device bioerodes.

WO 2008/036384 A3

C(Continuation). DOCUMENTS CONSIDERED TO BE RELEVANT		
Category*	Citation of document, with indication, where appropriate, of the relevant passages	Relevant to claim No.
X	WO 2005/027752 A (NMT MEDICAL INC [US]; CHANDUSZKO ANDRZEJ J [US]) 31 March 2005 (2005-03-31) the whole document	11-14, 16, 21
Y	paragraphs [0083], [0105], [0114] - [0116]; figure 48	16
X	EP 0 947 165 A (NISSHO KK [JP] NIPRO CORP [JP]) 6 October 1999 (1999-10-06) figures 1-7 paragraphs [0001], [0007], [0014] - [0017], [0019] - [0021]	11, 14, 21

FURTHER INFORMATION CONTINUED FROM PCT/ISA/ 210

This International Searching Authority found multiple (groups of) inventions in this international application, as follows:

1. claims: 11-16,21

A closure system for an interior body wall incision, comprising a seal and an anchor and a connector between the seal and the anchor, with the potentially special technical feature of openings in the connector positioned to receive tissue ingrowth.

2. claims: 17-18.

A closure system for an interior body wall incision, comprising a seal and an anchor, with the potentially special technical feature of a strip and an element, wherein the strip is coupled to the seal, the strip being extendable through the incision, and an element coupled to the strip, the strip being compressible upon application of tension to the element to cause folding of the strip.

3. claims: 19-20

A closure system for an interior body wall incision with the potentially special technical feature that it includes instructions for use.
